



Owner's Manual

Bass Amplifier CB-60XL CB-120XL

CUBE CUBE
60XL 120XL
BASS BASS

Owner's Manual

Bedienungsanleitung

Mode d'emploi

Manuale dell'utente

Manual del usuario

Manual do proprietário

Gebruikershandleiding

English

Deutsch

Français



Italiano

Español

Português

Nederlands

WARNING: To reduce the risk of fire or electric shock, do not expose this apparatus to rain or moisture.

  
ATTENTION: RISQUE DE CHOC ELECTRIQUE NE PAS OUVRIR
CAUTION: TO REDUCE THE RISK OF ELECTRIC SHOCK, DO NOT REMOVE COVER (OR BACK). NO USER-SERVICEABLE PARTS INSIDE. REFER SERVICING TO QUALIFIED SERVICE PERSONNEL.



The lightning flash with arrowhead symbol, within an equilateral triangle, is intended to alert the user to the presence of uninsulated "dangerous voltage" within the product's enclosure that may be of sufficient magnitude to constitute a risk of electric shock to persons.



The exclamation point within an equilateral triangle is intended to alert the user to the presence of important operating and maintenance (servicing) instructions in the literature accompanying the product.

INSTRUCTIONS PERTAINING TO A RISK OF FIRE, ELECTRIC SHOCK, OR INJURY TO PERSONS.

IMPORTANT SAFETY INSTRUCTIONS SAVE THESE INSTRUCTIONS

WARNING - When using electric products, basic precautions should always be followed, including the following:

1. Read these instructions.
2. Keep these instructions.
3. Heed all warnings.
4. Follow all instructions.
5. Do not use this apparatus near water.
6. Clean only with a dry cloth.
7. Do not block any of the ventilation openings. Install in accordance with the manufacturers instructions.
8. Do not install near any heat sources such as radiators, heat registers, stoves, or other apparatus (including amplifiers) that produce heat.
9. Do not defeat the safety purpose of the polarized or grounding-type plug. A polarized plug has two blades with one wider than the other. A grounding type plug has two blades and a third grounding prong. The wide blade or the third prong are provided for your safety. If the provided plug does not fit into your outlet, consult an electrician for replacement of the obsolete outlet.
10. Protect the power cord from being walked on or pinched particularly at plugs, convenience receptacles, and the point where they exit from the apparatus.
11. Only use attachments/accessories specified by the manufacturer.
12. Unplug this apparatus during lightning storms or when unused for long periods of time.
13. Refer all servicing to qualified service personnel. Servicing is required when the apparatus has been damaged in any way, such as power-supply cord or plug is damaged, liquid has been spilled or objects have fallen into the apparatus, the apparatus has been exposed to rain or moisture, does not operate normally, or has been dropped.

For the U.K.

WARNING: THIS APPARATUS MUST BE EARTHED

IMPORTANT: THE WIRES IN THIS MAINS LEAD ARE COLOURED IN ACCORDANCE WITH THE FOLLOWING CODE.
GREEN-AND-YELLOW: EARTH, BLUE: NEUTRAL, BROWN: LIVE

As the colours of the wires in the mains lead of this apparatus may not correspond with the coloured markings identifying the terminals in your plug, proceed as follows:

The wire which is coloured GREEN-AND-YELLOW must be connected to the terminal in the plug which is marked by the letter E or by the safety earth symbol  or coloured GREEN or GREEN-AND-YELLOW.

The wire which is coloured BLUE must be connected to the terminal which is marked with the letter N or coloured BLACK.

The wire which is coloured BROWN must be connected to the terminal which is marked with the letter L or coloured RED.

Owner's Manual

Bass Amplifier CB-60XL CB-120XL



CUBE CUBE 60XL 120XL BASS BASS

CUBE-60XL BASS

This superior performance DSP bass amp offers 60 W output, and is equipped with a custom 25 cm (10 inch) two-way coaxial speaker.

CUBE-120XL BASS

This high-powered DSP bass amp delivers 120 W output, and is equipped with a custom 30 cm (12 inch) two-way coaxial speaker.

- Thanks to Roland's proprietary FFP technology, this unit is able to deliver a sound that's a lot more powerful than you'd expect, given its small size.

FFP (Feed Forward Processing) is system control technology that optimizes the performance of the amp, speakers, and cabinet characteristics according to the signals being input, based on the results of analyses of the operation and behavior of each section of existing amp systems.

Eight different COSM Amp Types (p. 5)

- Offers eight different COSM amp types modeled on some of the renowned, vintage amps of yesteryear, and includes the originals SUPER FLAT and SUPER LOW. With so many choices, you're sure to be able to accommodate almost any style of music.

Composite Object Sound Modeling (COSM) is Roland's innovative and powerful sound modeling technology. COSM analyzes the many factors that make up the original sound, such as the electrical and physical characteristics of the original, and then produces a digital model that can reproduce the same sound.

LOOPER function lets you record, play back, and overdub the phrases you perform (p. 14)

- You can record a phrase you play, and then enjoy performing with that phrase as your backing. Maximum recording time is approximately 80 seconds.

The Solo function lets you store the settings for a sound, then call them up later (p. 13)

- Thanks to this feature, you can switch between a backing-use sound, solo-use sound, or other sound during a performance. If you connect a foot switch (optional), you'll be able to switch Solo on/off using your foot.

Effects include COMP/DRIVE, EFX and an independent DELAY, REVERB (p. 4, p. 6, p. 7)

- Comes with two kinds of EFX, CHORUS and POLY OCTAVE.
- Foot switch (optional) can be used to switch COMP/DRIVE, EFX, and DELAY/REVERB on and off

Provides an AUX IN jack, which is useful for practice, and a tuner function (p. 10, p. 12)

- If you connect a CD player or digital audio player, you'll be able to play along while listening to some music.
- The tuner function supports flat tuning, as well as five-string and six-string basses. In addition, it also offers chromatic tuning.

Before using this unit, carefully read the sections entitled: "IMPORTANT SAFETY INSTRUCTIONS" (inside front cover), "USING THE UNIT SAFELY" (p. 2), and "IMPORTANT NOTES" (p. 3). These sections provide important information concerning the proper operation of the unit. Additionally, in order to feel assured that you have gained a good grasp of every feature provided by your new unit, Owner's manual should be read in its entirety. The manual should be saved and kept on hand as a convenient reference.

Copyright © 2010 ROLAND CORPORATION

All rights reserved. No part of this publication may be reproduced in any form without the written permission of ROLAND CORPORATION. Roland, COSM, and POWER SQUEEZER are registered trademarks of Roland Corporation in the United States and/or other countries.

USING THE UNIT SAFELY

INSTRUCTIONS FOR THE PREVENTION OF FIRE, ELECTRIC SHOCK, OR INJURY TO PERSONS

About ⚠ WARNING and ⚠ CAUTION Notices

⚠ WARNING	Used for instructions intended to alert the user to the risk of death or severe injury should the unit be used improperly.
⚠ CAUTION	Used for instructions intended to alert the user to the risk of injury or material damage should the unit be used improperly. * Material damage refers to damage or other adverse effects caused with respect to the home and all its furnishings, as well to domestic animals or pets.

About the Symbols

	The ⚠ symbol alerts the user to important instructions or warnings. The specific meaning of the symbol is determined by the design contained within the triangle. In the case of the symbol at left, it is used for general cautions, warnings, or alerts to danger.
	The 🔥 symbol alerts the user to items that must never be carried out (are forbidden). The specific thing that must not be done is indicated by the design contained within the circle. In the case of the symbol at left, it means that the unit must never be disassembled.
	The ⚡ symbol alerts the user to things that must be carried out. The specific thing that must be done is indicated by the design contained within the circle. In the case of the symbol at left, it means that the power-cord plug must be unplugged from the outlet.

ALWAYS OBSERVE THE FOLLOWING

⚠ WARNING

Connect mains plug of this model to a mains socket outlet with a protective earthing connection.	
Do not open or perform any internal modifications on the unit.	
Do not attempt to repair the unit, or replace parts within it (except when this manual provides specific instructions directing you to do so). Refer all servicing to your retailer, the nearest Roland Service Center, or an authorized Roland distributor, as listed on the "Information" page.	
Never install the unit in any of the following locations. <ul style="list-style-type: none"> • Subject to temperature extremes (e.g., direct sunlight in an enclosed vehicle, near a heating duct, on top of heat-generating equipment); or are • Damp (e.g., baths, washrooms, on wet floors); or are • Exposed to steam or smoke; or are • Subject to salt exposure; or are • Humid; or are • Exposed to rain; or are • Dusty or sandy; or are • Subject to high levels of vibration and shakiness. 	
Make sure you always have the unit placed so it is level and sure to remain stable. Never place it on stands that could wobble, or on inclined surfaces.	
The unit should be connected to a power supply only of the type described as marked on the rear side of unit.	
Do not excessively twist or bend the power cord, nor place heavy objects on it. Doing so can damage the cord, producing severed elements and short circuits. Damaged cords are fire and shock hazards!	
This unit, either alone or in combination with an amplifier and headphones or speakers, may be capable of producing sound levels that could cause permanent hearing loss. Do not operate for a long period of time at a high volume level, or at a level that is uncomfortable. If you experience any hearing loss or ringing in the ears, you should immediately stop using the unit, and consult an audiologist.	
Do not place containers containing liquid on this product. Never allow foreign objects (e.g., flammable objects, coins, wires) or liquids (e.g., water or juice) to enter this product. Doing so may cause short circuits, faulty operation, or other malfunctions.	
Immediately turn the power off, remove the power cord from the outlet, and request servicing by your retailer, the nearest Roland Service Center, or an authorized Roland distributor, as listed on the "Information" page when: <ul style="list-style-type: none"> • The power-supply cord or the plug has been damaged; or • If smoke or unusual odor occurs • Objects have fallen into, or liquid has been spilled onto the unit; or • The unit has been exposed to rain (or otherwise has become wet); or • The unit does not appear to operate normally or exhibits a marked change in performance. 	

⚠ WARNING

In households with small children, an adult should provide supervision until the child is capable of following all the rules essential for the safe operation of the unit.	
Protect the unit from strong impact. (Do not drop it!)	
Do not force the unit's power-supply cord to share an outlet with an unreasonable number of other devices. Be especially careful when using extension cords—the total power used by all devices you have connected to the extension cord's outlet must never exceed the power rating (watts/ amperes) for the extension cord. Excessive loads can cause the insulation on the cord to heat up and eventually melt through.	
Before using the unit in a foreign country, consult with your retailer, the nearest Roland Service Center, or an authorized Roland distributor, as listed on the "Information" page.	

⚠ CAUTION

The unit should be located so that its location or position does not interfere with its proper ventilation.	
Always grasp only the plug on the power-supply cord when plugging into, or unplugging from an outlet.	
At regular intervals, you should unplug the power plug and clean it by using a dry cloth to wipe all dust and other accumulations away from its prongs. Also, disconnect the power plug from the power outlet whenever the unit is to remain unused for an extended period of time. Any accumulation of dust between the power plug and the power outlet can result in poor insulation and lead to fire.	
Try to prevent cords and cables from becoming entangled. Also, all cords and cables should be placed so they are out of the reach of children.	
Never climb on top of, nor place heavy objects on the unit.	
Never handle the power cord or its plug with wet hands when plugging into, or unplugging from, an outlet.	
Before moving the unit, disconnect the power plug from the outlet, and pull out all cords from external devices.	
Before cleaning the unit, turn off the power and unplug the power cord from the outlet (p. 7).	
Whenever you suspect the possibility of lightning in your area, pull the plug on the power cord out of the outlet.	
Do not remove the speaker grille and speaker by any means. Speaker not user replaceable. Shock hazardous voltages and currents are present inside the enclosure.	

IMPORTANT NOTES

Power Supply

- Do not connect this unit to same electrical outlet that is being used by an electrical appliance that is controlled by an inverter (such as a refrigerator, washing machine, microwave oven, or air conditioner), or that contains a motor. Depending on the way in which the electrical appliance is used, power supply noise may cause this unit to malfunction or may produce audible noise. If it is not practical to use a separate electrical outlet, connect a power supply noise filter between this unit and the electrical outlet.
- Before connecting this unit to other devices, turn off the power to all units. This will help prevent malfunctions and/or damage to speakers or other devices.
- Although the LEDs are switched off when the POWER switch is switched off, this does not mean that the unit has been completely disconnected from the source of power. If you need to turn off the power completely, first turn off the POWER switch, then unplug the power cord from the power outlet. For this reason, the outlet into which you choose to connect the power cord's plug should be one that is within easy reach and readily accessible.

Placement

- Using the unit near power amplifiers (or other equipment containing large power transformers) may induce hum. To alleviate the problem, change the orientation of this unit; or move it farther away from the source of interference.
- This device may interfere with radio and television reception. Do not use this device in the vicinity of such receivers.
- Noise may be produced if wireless communications devices, such as cell phones, are operated in the vicinity of this unit. Such noise could occur when receiving or initiating a call, or while conversing. Should you experience such problems, you should relocate such wireless devices so they are at a greater distance from this unit, or switch them off.
- Do not expose the unit to direct sunlight, place it near devices that radiate heat, leave it inside an enclosed vehicle, or otherwise subject it to temperature extremes. Also, do not allow lighting devices that normally are used while their light source is very close to the unit (such as a piano light), or powerful spotlights to shine upon the same area of the unit for extended periods of time. Excessive heat can deform or discolor the unit.
- When moved from one location to another where the temperature and/or humidity is very different, water droplets (condensation) may form inside the unit. Damage or malfunction may result if you attempt to use the unit in this condition. Therefore, before using the unit, you must allow it to stand for several hours, until the condensation has completely evaporated.
- Do not allow rubber, vinyl, or similar materials to remain on this unit for long periods of time. Such objects can discolor or otherwise harmfully affect the finish.
- Do not paste stickers, decals, or the like to this instrument. Peeling such matter off the instrument may damage the exterior finish.
- Depending on the material and temperature of the surface on which you place the unit, its rubber feet may discolor or mar the surface. You can place a piece of felt or cloth under the rubber feet to prevent this from happening. If you do so, please make sure that the unit will not slip or move accidentally.
- Do not put anything that contains water (e.g., flower vases) on this unit. Also, avoid the use of insecticides, perfumes, alcohol, nail polish, spray cans, etc., near the unit. Swiftly wipe away any liquid that spills on the unit using a dry, soft cloth.

Maintenance

- For everyday cleaning wipe the unit with a soft, dry cloth or one that has been slightly dampened with water. To remove stubborn dirt, use a cloth impregnated with a mild, non-abrasive detergent. Afterwards, be sure to wipe the unit thoroughly with a soft, dry cloth.
- Never use benzine, thinners, alcohol or solvents of any kind, to avoid the possibility of discoloration and/or deformation.

Repairs and Data

- Please be aware that unit settings or the contents of the solo function stored in memory may be lost when the unit is sent for servicing. Important data should always be written down on paper. Roland assumes no liability with respect to recovery of any lost data.

Additional Precautions

- Please be aware that unit settings or the contents of the solo function stored in memory can be irretrievably lost as a result of a malfunction or the improper operation of the unit. To protect yourself against the risk of losing important data, we recommend that you periodically write down on paper any important data you have stored in the unit's memory.
- Roland Corporation assumes no liability with respect to recovery of any lost unit settings or contents of the solo function stored in memory.
- Use a reasonable amount of care when using the unit's buttons, sliders, or other controls; and when using its jacks and connectors. Rough handling can lead to malfunctions.
- When connecting / disconnecting all cables, grasp the connector itself—never pull on the cable. This way you will avoid causing shorts, or damage to the cable's internal elements.
- A small amount of heat will radiate from the unit during normal operation.
- To avoid disturbing your neighbors, try to keep the unit's volume at reasonable levels. You may prefer to use headphones, so you do not need to be concerned about those around you.
- When you need to transport the unit, package it in the box (including padding) that it came in, if possible. Otherwise, you will need to use equivalent packaging materials.
- Some connection cables contain resistors. Do not use cables that incorporate resistors for connecting to this unit. The use of such cables can cause the sound level to be extremely low, or impossible to hear. For information on cable specifications, contact the manufacturer of the cable.
- No sound is output from this unit's speaker or any external speaker when the RECORDING OUT/PHONES jack is in use.
- Due to the structural design of this instrument, small pets or other animals could end up getting trapped inside it. If such a situation is encountered, you must immediately switch off the power and disconnect the power cord from the outlet. You should then consult with the retailer from whom the instrument was purchased, or contact the nearest Roland Service Center.
- Wrap the power cord around the cord hook when transporting or storing the unit.
- For CUBE-120XL BASS only
When connecting to an external speaker, make sure the speaker conforms to the following specifications.
Impedance: 8 ohms or less
Allowable power input: 120 watts or greater
- For CUBE-120XL BASS only
Only use speaker cable to connect the speaker. Do not use any shielded cable designed for use with guitars.
- Do not insert hands, fingers, etc, into the openings in the unit. In particular, if the unit is to be used in households with small children, always provide adult supervision to ensure that children keep their hands and feet out of these openings.

Copyright

- Recording, duplication, distribution, sale, lease, performance, or broadcast of copyrighted material (musical works, visual works, broadcasts, live performances, etc.) belonging to a third party in part or in whole without the permission of the copyright owner is forbidden by law.
- Do not use this unit for purposes that could infringe on a copyright held by a third party. We assume no responsibility whatsoever with regard to any infringements of third-party copyrights arising through your use of this unit.

Trademarks

- The product names mentioned in this document are trademarks or registered trademarks of their respective owners. In this manual, these names are used because it is the most practical way of describing the sounds that are simulated using COSM technology.

Panel Descriptions

Control Panel

CUBE-60XL BASS

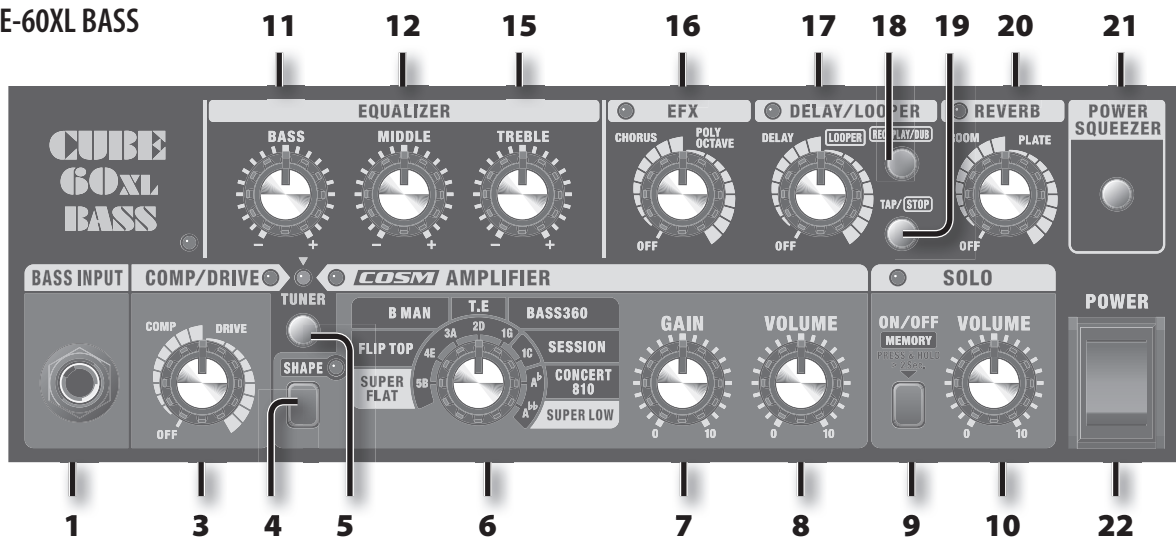

CUBE-120XL BASS

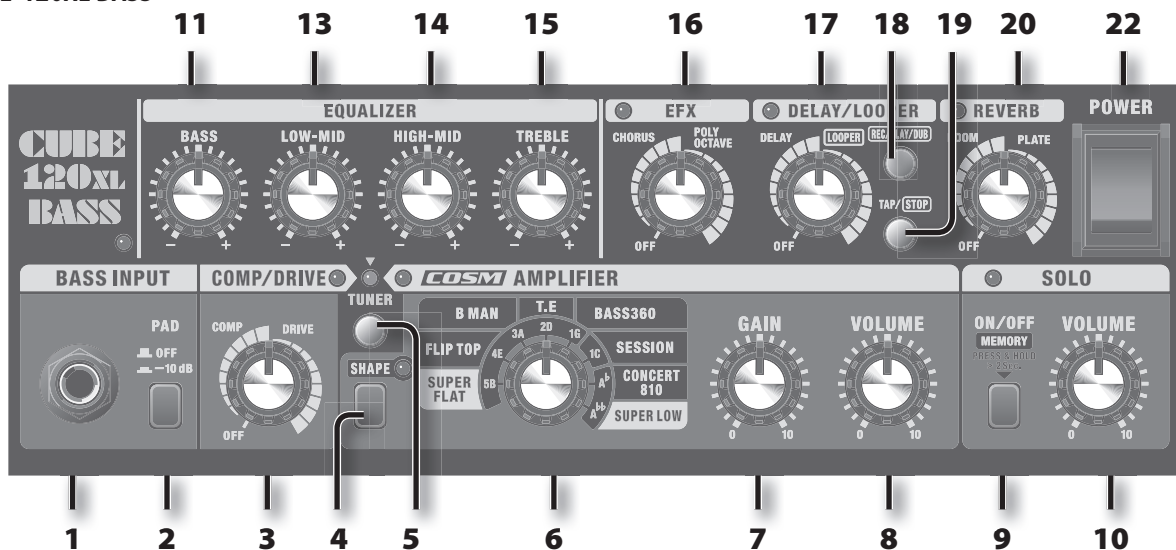

1. BASS INPUT Jack

Connect your bass here.

2. [PAD] Switch (CUBE-120XL BASS only)

This adjusts the degree of amplification in the BASS INPUT circuitry (the input sensitivity).

Switching this on lowers the input sensitivity (-10 dB).

Switch this on if distortion occurs in this device's input section as the result of using basses with high output signal levels or using connected devices. We recommend that this be switched off for ordinary use.

3. [COMP/DRIVE] Knob

Turn this knob to COMP (Compression) or DRIVE to switch to that effect. Turn the knob to adjust the amount of effect applied.

You can also turn COMP/DRIVE on and off using optional foot switches.

Knob Position	Description
COMP	This effect evens out the input signal levels, thus evening out the sound. Turning the knob to the right increases the compression effect.
DRIVE	This effect adds distortion to the sound. Turning the knob to the right increases the distortion.

The COMP/DRIVE indicator lights up when COMP or DRIVE is on, and goes out when turned off.

4. [SHAPE] Switch

This effect alters the COSM amps' tonal characteristics. The particular effect obtained varies according to the amp selected with the Type switch (6).

5. [TUNER] Switch

Use this when you want to tune your bass. When you turn on the switch, it will light red, and you'll be able to use the Tuner function.

For more detailed information, refer to "Using the Tuner Function" (p. 12).

COSM AMPLIFIER

6. Type Switch

Use this to select the COSM amp type.

If the Tuner function is on, use this to select the string that you're tuning.

Type	Description
SUPER FLAT	<p>An original amp featuring a wide-range frequency response.</p> <p>This amp type provides faithful reproduction of the connected bass's own sound.</p> <p>This is a great type for all kinds of connected instrument.</p> <p>[SHAPE] Switch: ON</p> <p>This produces a mild tone with a fat midrange, providing a sound that is perfect for fretless basses, including fretless electric and wood acoustic basses.</p>
FLIP TOP	<p>Models the Ampeg B-15 (1 x 15"). This amp provided the underpinning for many of the most famous Motown hits.</p> <p>It features a fat sound, while the amp's compact cabinet produces a distinct contour.</p> <p>[SHAPE] Switch: ON</p> <p>Offers more nuances of your picking expression.</p>
B MAN	<p>Models the Fender Bassman 100 (4 x 12").</p> <p>This amp has been a favorite since the inception of electric basses. It features the sonic characteristics of tube amps, whereby increasing the distortion slightly yields a fatter sound.</p> <p>[SHAPE] Switch: ON</p> <p>Offers a tone with boosted midrange fatness.</p>
T.E	<p>Models the Trace Elliot AH600SMX + 1048 (4 x 10") + 1518 (1 x 15"). This amp was used widely by rock bands in the 1980s. Its wide range, clear attack, and other features make it a great amp for all kinds of performance situations.</p> <p>[SHAPE] Switch: ON</p> <p>Offers more attack.</p>
BASS360	<p>Models the acoustic 360 (1 x 18").</p> <p>This amp was used in the '70s not only by jazz bassists, but by funk and hard rock players as well. The tone features a warm low end with a midrange that maintains a clear contour, even with finger picking.</p> <p>[SHAPE] Switch: ON</p> <p>Offers more nuances of your picking expression.</p>
SESSION	<p>Models the SWR SM-400 + Goliath (4 x 10") + Big Ben (1 x 18"). This tweeter-equipped amp is representative of the "L.A. Sound" of the '80s. It features a wide-range tone that balances presence in the low end with a clear, open sound.</p> <p>[SHAPE] Switch: ON</p> <p>Offers a tight tone with a cut midrange.</p>
CONCERT 810	<p>Models the Ampeg SVT + 810E (8 x 10").</p> <p>This amp typifies the rock sound that relied heavily on combinations of high-output tube amp sections and large-sized cabinets.</p> <p>The characteristic sound is one of overwhelming low-frequency sound pressure.</p> <p>[SHAPE] Switch: ON</p> <p>Offers extra heavy bottom sound.</p>

Type	Description
SUPER LOW	<p>In addition to the wide-range frequency response that SUPER FLAT offers, this original amp also provides for the reproduction of heavy, deeply resounding bass sounds.</p> <p>While faithfully reproducing the inherent sound of the bass you've connected, this also provides for deeply resounding bass sounds. Additionally, it offers a sufficient amount of clarity, so sounds don't get buried by the low-frequency content.</p> <p>[SHAPE] Switch: ON</p> <p>The well-defined heavy bass sounds are boosted.</p>

* The product names mentioned in this document are trademarks or registered trademarks of their respective owners. In this manual, these names are used because it is the most practical way of describing the sounds that are simulated using COSM technology.

7. [GAIN] Knob

This adjusts the preamp section's input level.

Turning the knob to the right increases the gain.

HINT

- Adjust the knob until the value is as high as you can get it without causing the sound to distort.
- Using a high gain setting allows you to get an overdrive sound.

8. [VOLUME] Knob

Adjusts the overall volume.

* This does not work with respect to DI OUT (p. 9).

SOLO Function

This lets you save the panel settings for sounds you create (such as amp type, gain, equalizer, and various effects) and call them up later.

On the CUBE-60XL BASS/CUBE-120XL BASS, this function is called "SOLO."

The SOLO function is handy in situations like these:

- When you want to switch the amp type and effect at the same time.
- When you want to switch the equalizer settings and volume level at the same time.

9. SOLO [ON/OFF] Switch

This saves panel settings and calls up it.

10. [VOLUME] Knob

This adjusts the volume level for the called-up settings.

* For information on how to use the SOLO function, refer to "Using the SOLO Function" (p. 13).

EQUALIZER

CUBE-60XL BASS

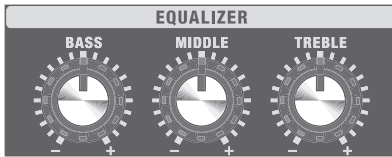

11. [BASS] Knob

Adjusts the tone quality of the lower range.

12. [MIDDLE] Knob

Adjusts the tone quality of the midrange.

15. [TREBLE] Knob

Adjusts the tone quality of the upper range.

CUBE-120XL BASS

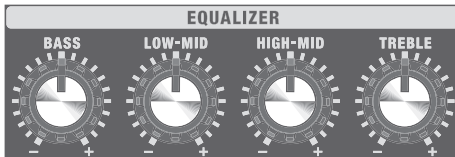

11. [BASS] Knob

Adjusts the tone quality of the lower range.

13. [LOW-MID] Knob

Adjusts the tone quality of the lower midrange.

14. [HIGH-MID] Knob

Adjusts the tone quality of the upper midrange.

15. [TREBLE] Knob

Adjusts the tone quality of the upper range.

EFX

16. [EFX] Knob

Turn this knob to CHORUS or POLY OCTAVE to select the corresponding effect. Turn the knob to adjust the amount of effect applied.

The ON indicator lights up when EFX is turned on, and goes out when EFX is turned off. You can also turn EFX on and off using optional foot switches.

* Graduations for CHORUS and POLY OCTAVE on a panel are for reference. Be sure to check the sound as you adjust the effects.



Knob Position	Description
CHORUS	In this effect, a slightly detuned sound is added to the original sound, giving the sound greater breadth and fullness. Turning the knob to the right increases the rate and deepens the chorus effect.
POLY OCTAVE	This adds sound lowered by an octave to the original sound. Since you can play chords even when using this effect, you can use it to fatten the sound of your chordal playing as well. Turning the knob to the right increases the effect sound.

DELAY/LOOPER

17. [DELAY/LOOPER] Knob

You can switch to DELAY or the LOOPER function by positioning this knob.

When the knob is at DELAY, this functions as a delay.

When the knob is positioned at LOOPER, this functions as a looper.



* The scale indications for DELAY and LOOPER are just a general guide. Be sure to check the actual sound as you adjust the effect.

The indicator lights up when DELAY or LOOPER is on and goes out when it's off.

To use DELAY

17. [DELAY/LOOPER] Knob

Set the knob in the position to turn DELAY on. The position of the knob within this range adjusts the volume of the delay sound.

You can also switch DELAY on and off using an optional footswitch pedal.

18. [REC/PLAY/DUB] Switch

This will blink in synchronization with the delay time.

19. [TAP/STOP] Switch

Use this to set the delay time. When you press the switch twice, the delay time will be set to the time interval at which you pressed the switch. The maximum length is 2000 ms.

Setting the Delay Time for Short Delay

If you hold down the switch for one second or longer, the delay time will be set to 30 ms. Each time you then press the [REC/PLAY/DUB] switch, the delay time will change over four steps (30 ms/50 ms/70 ms/90 ms) to a maximum of 90 ms.

* The short delay cannot be set using the foot switch.

To use the LOOPER function

17. [DELAY/LOOPER] Knob

Set the knob in the LOOPER range to turn on the LOOPER function. The position of the knob within this range specifies the LOOPER function's playback volume.

18. [REC/PLAY/DUB] Switch

Use this switch to record, play back, and overdub.

19. [TAP/STOP] Switch

This switch stops playback or erases the recording.

If the [DELAY/LOOPER] knob is in the LOOPER range, this switch stops the LOOPER or erases the recording.

- * For details on using the LOOPER function, refer to "Using the LOOPER" (p. 14).
- * When the knob is positioned at LOOPER, no delay effect is applied. To use the LOOPER and DELAY simultaneously, refer to "Using the LOOPER Function and DELAY at the Same Time" (p. 15).

REVERB

20. [REVERB] Knob

You can switch between use of two types of reverb by changing the position of the knob. You can adjust the intensity of the effect by varying the knob position.

The indicator lights up when REVERB is on and goes out when the effect is off.

You can also switch REVERB on and off using an optional footswitch pedal.



Knob Position	Description
ROOM	This reverb simulates the short reverberant sound heard within a room. Turning the knob clockwise makes the effect progressively more intense.
PLATE	This is a plate reverb. This reverb features high-end sustain. Turning the knob clockwise makes the effect progressively more intense.

POWER SQUEEZER (CUBE-60XL BASS only)

21. [POWER SQUEEZER] Switch

The switch lights in red when the POWER SQUEEZER function is on and goes out when the POWER SQUEEZER is off.

Switching on the POWER SQUEEZER function allows you to reduce the amp's output to volume levels that are suitable for the average home.

Switching this on allows you to produce a sound that preserves the same tone and balance at volume levels that are suitable for the average home.

- * The POWER SQUEEZER function affects only sounds input through the BASS INPUT jack. It has no effect on sounds input via the AUX IN jack.
- * The POWER SQUEEZER function will also affect the output from the LINE OUT and RECORDING OUT/PHONES jacks; this is normal and does not indicate a malfunction.



POWER

22. [POWER] Switch

This switches the power on and off.

Switching the Power On and Off

- * Turn on power to your various devices in the order specified. By turning on devices in the wrong order, you risk causing malfunction and/or damage to speakers and other devices.
1. Make sure that all [VOLUME] knobs on the CUBE-60XL BASS/ CUBE-120XL BASS and all the connected devices are set to 0.
 2. Turn on all the devices connected to the CUBE-60XL BASS/ CUBE-120XL BASS's input jacks (BASS INPUT jack and AUX IN jack).
 3. Turn on the CUBE-60XL BASS/CUBE-120XL BASS.
 - * Always make sure to have the volume level turned down before switching on power. Even with the volume all the way down, you may still hear some sound when the power is switched on, but this is normal, and does not indicate a malfunction.
 - * This unit is equipped with a protection circuit. A brief interval (a few seconds) after power up is required before the unit will operate normally.
 4. Adjust the volume levels for the devices.
 5. Before switching off the power, lower the volume on all the connected devices and then TURN OFF the devices in the reverse order to which they were switched on.
 - * If you need to turn off the power completely, first turn off the POWER switch, then unplug the power cord from the power outlet. Refer to Power Supply (p. 3).

Rear Panel

CUBE-60XL BASS

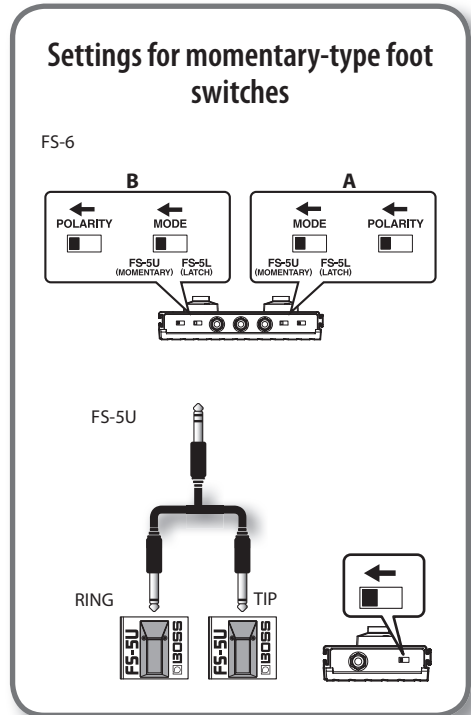
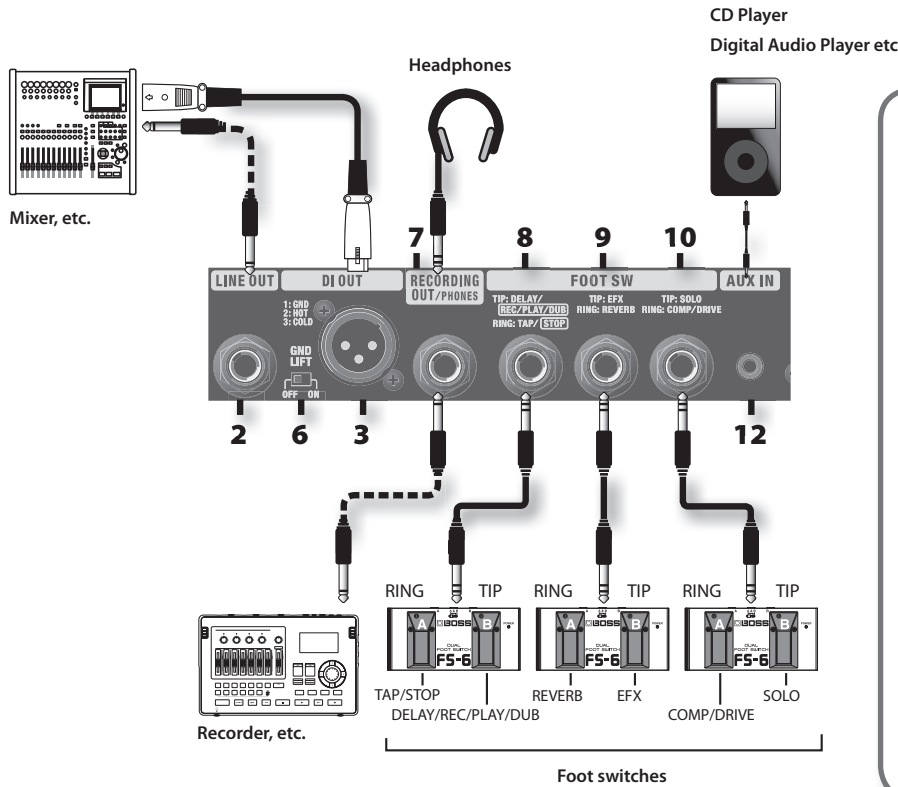

CUBE-120XL BASS

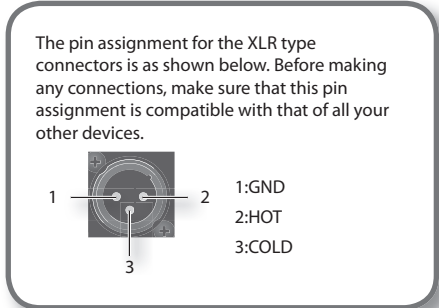
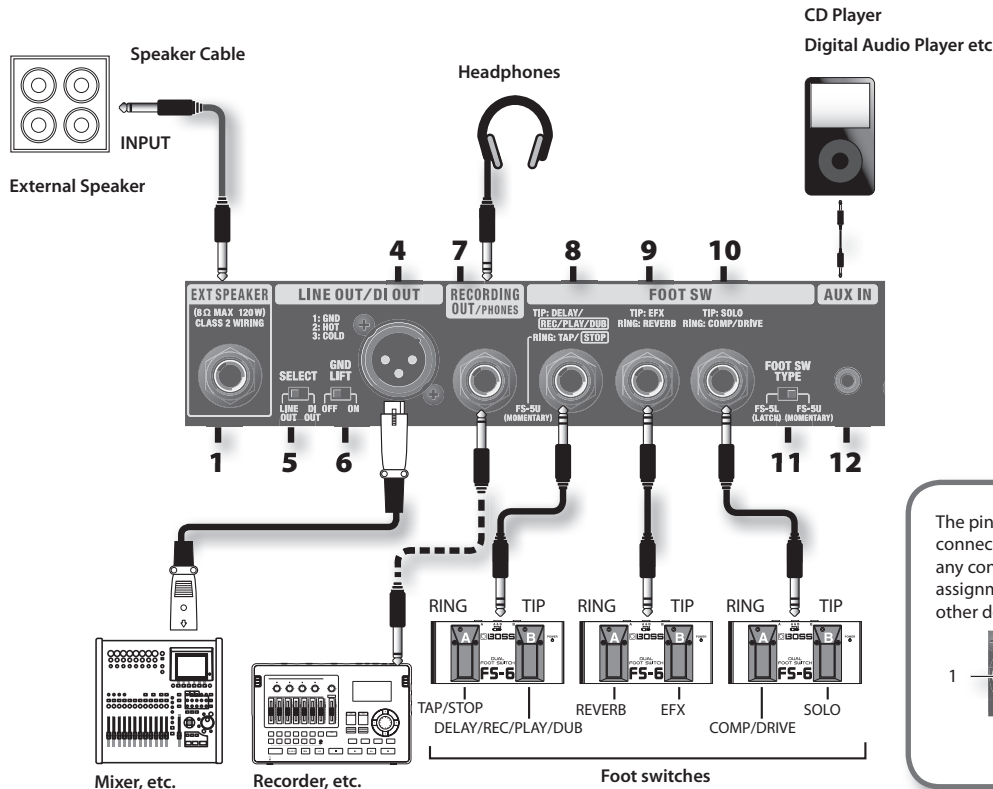

* To prevent malfunction and/or damage to speakers or other devices, always turn down the volume, and turn off the power on all devices before making any connections.

EXT SPEAKER (CUBE-120XL BASS only)

1. EXT SPEAKER Jack

This is for connecting an external speaker.

When an external speaker is connected, sound is played both from the external speaker and from the unit's built-in speaker.

- * **When connecting to an external speaker, make sure the speaker conforms to the following specifications.**

Impedance: 8 ohms or less

Allowable power input: 120 watts or greater

- * **Only use speaker cable to connect the speaker. Do not use any shielded cable designed for use with guitars.**

LINE OUT/DI OUT

2. LINE OUT Jack (CUBE-60XL BASS)

This is for connecting a PA system, recorder, or other external equipment.

This features COSM speaker modeling, enabling production of impressive bass-amp sound.

You can use this in conjunction with an external PA system, or to record your performance via direct line while monitoring the sound from the CUBE's speaker.

- * **The sound from AUX IN is not output from LINE OUT jack.**

3. DI OUT Jack (CUBE-60XL BASS)

Use this to connect to external PAs and other such systems. Signals input to the BASS INPUT jack are output as is.

This professional-grade feature includes a tough, reliable XLR-type connector and ground lift switch.

4. LINE OUT/DI OUT Jack (CUBE-120XL BASS)

Use this to connect to external PAs and other such systems.

This professional-grade feature includes a tough, reliable XLR-type connector and ground lift switch.

5. LINE OUT/DI OUT [SELECT] Switch (CUBE-120XL BASS)

You can switch the sound that is output from the CUBE-120XL BASS's LINE OUT/DI OUT to suit the particular application.

Switch	Description
DI OUT	Signals input to the BASS INPUT jack are output as is. Other than the PAD switch, none of the CUBE's knobs affect the LINE OUT/DI OUT output.
LINE OUT	The sound is changed by the settings of the CUBE's knobs.

6. [GND LIFT] Switch

Loop hum noise may occur when other external devices are connected to the CUBE-60XL/CUBE-120XL. In such instances, you may be able to mitigate the problem by switching the position of the [GND LIFT] switch. The [GND LIFT] switch should be normally set to OFF.

Switch	Description
ON	Pin 1 is disconnected from the CUBE's ground.
OFF	Pin 1 connects to the CUBE's ground.

RECORDING OUT/PHONES

7. RECORDING OUT/PHONES Jack

This functions either as an output jack for recording or as a phones jack.

This features COSM speaker modeling, enabling production of impressive bass sound.

Adjust the volume using the [VOLUME] knobs for the COSM AMP and the SOLO function.

- * **When a plug is connected to this jack, no sound is played from either the unit or any connected external speaker. This is handy at night or in other situations when you want to avoid high-volume sound from the speakers.**

When using as an output jack for recording

Use a monaural 1/4" phone plug to connect a recorder or other recording device.

When using as a headphones jack

Connect headphones.

FOOT SW

By connecting a foot switch (BOSS FS-5U or FS-6; sold separately), you'll be able to use your foot to turn COMP/DRIVE, EFX, REVERB, and DELAY on/off, and control the LOOPER function. The connection diagram at the previous page is a connection example that shows how to use a momentary-type foot switch (FS-5U, FS-6). For details on connections and settings when using a latch-type foot switch (BOSS FS-5L; sold separately), refer to "Using a Latch-type Foot Switch" (p. 11).

8. TIP: DELAY/REC/PLAY/DUB RING: TAP/STOP

Switch	Description
TIP	If the [DELAY/LOOPER] knob is in the DELAY area, the DELAY will be switched on/off. If the knob is in the LOOPER area, the foot switch will have the same function as the panel's [REC/PLAY/DUB] switch.
RING	The foot switch will have the same function as the [TAP/STOP] switch.

- * **You must use a momentary-type foot switch with the RING (TAP/STOP) of this jack. It will not work correctly with a latch-type foot switch (p. 11).**

9. TIP: EFX RING: REVERB

Switch	Description
TIP	The foot switch will turn on/off the effect selected by the [EFX] knob.
RING	The foot switch will turn on/off the REVERB set by the [REVERB] knob.

10. TIP: SOLO RING: COMP/DRIVE

Switch	Description
TIP	The foot switch will turn SOLO on/off.
RING	The foot switch will turn on/off the compression or drive set by the [COMP/DRIVE] knob.

11. [FOOT SW TYPE] Switch (CUBE-120XL BASS only)

This selects the type of foot switch that is connected.

When shipped from the factory, the CUBE-60XL BASS's FOOT SW TYPE is set to the momentary type. For details on how to change this setting, refer to "Using a Latch-type Foot Switch" (p. 11).

- * The CUBE's FOOT SW (foot switch) jacks are TRS type jacks, and support plugs of the type shown in the illustration. Use TRS cables to connect your foot switch.

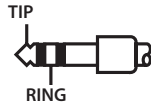

AUX IN

12. AUX IN Jack

This lets you connect a CD player, digital audio player, electronic instrument, or other such device and play it at the same time as the bass.

This accepts a stereo miniature phone plug. However, the speaker and RECORDING OUT/PHONES output is monaural. Use a cable (sold separately) that's appropriate for the device you're connecting.

- * Determine the volume level by adjusting the volume control of the connected device.
- * When connection cables with resistors are used, the volume level of equipment connected to the AUX IN jack may be low. If this happens, use connection cables that do not contain resistors.

Using a Latch-type Foot Switch

The CUBE-60XL BASS/CUBE-120XL BASS also support latch-type foot switches. If you're using a latch-type foot switch, make the following settings.

FOOT SW TYPE setting

There are two types of foot switches.

Type	Operation
Momentary type (BOSS FS-5U, etc.)	This type remains on (or off) while depressed and switches off (or on) when released.
Latch type (BOSS FS-5L, etc.)	This type switches on or off each time it is depressed.

* The BOSS FS-6 can operate as either a momentary or latch-type pedal switch.

CUBE-60XL BASS

At the factory settings, the momentary type is selected. You can change this setting as follows.

- To specify the latch type
Turn on the power while holding down the [TAP/STOP] switch.
 - To specify the momentary type
Turn on the power while holding down the [REC/PLAY/DUB] switch.
- * The setting you specify is remembered even while the power is turned off.

CUBE-120XL BASS

Set the [FOOT SW TYPE] switch on the rear panel to FS-5L (LATCH).



Foot Switch Settings

BOSS FS-5L

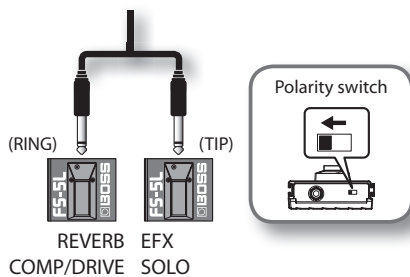

BOSS FS-6

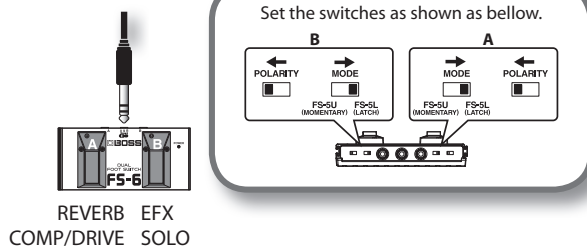

BOSS FS-5L+FS-5U

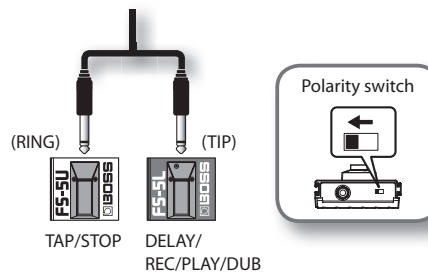

BOSS FS-6

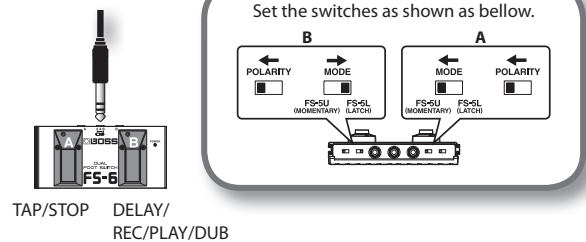

* Even if FOOT SW TYPE is set to FS-5L (LATCH), you must always use a momentary-type foot switch for TAP/STOP. This function will not work correctly with a latch-type foot switch.

Important Notes When Using a Latch-type Footswitch Pedal

The on/off state of the footswitch pedal takes precedence over the control panel for switching COMP/DRIVE, EFX, DELAY, or REVERB on and off.

However, the on or off states of COMP/DRIVE, EFX, DELAY, or REVERB stored in memory using the SOLO function take precedence when saved SOLO-function panel settings are called up. Such cases may result in conflicting indicator displays on the control panel and the footswitch pedal, but this is not a malfunction.

Convenient Applications

You can use either of the following settings to control operation when the panel settings for COMP/DRIVE, EFX, DELAY, and REVERB are called up using the SOLO function.

Foot switch priority mode

Make the on/off state of the footswitch pedal always take priority.

To make the setting:
Hold down the [SHAPE] switch and switch on the power.

Memory priority mode (factory setting)

Make the on/off state saved using the SOLO function take priority.

To make the setting:
Hold down the [TUNER] switch and switch on the power.

* The changed setting remains in memory after the power is switched off.

Using the Tuner Function

CUBE-60XL BASS/CUBE-120XL BASS are equipped with a tuner function. In addition to manual tuning, you can also use it as a chromatic tuner.

- * Use manual tuning when the strings are substantially out of tune (such as after changing strings).
- * When using the tuner function, no sound is played from the speaker, the REC OUT/PHONES jack, or the LINE OUT jack.
- * The sound input to the AUX IN jack is output.

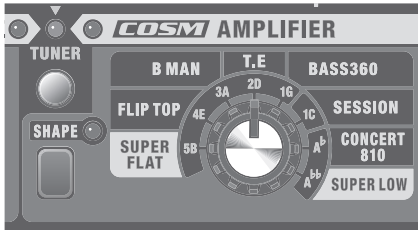

Manual Tuning

1. Press the [TUNER] switch.
The unit enters the Tuner mode and the [TUNER] switch lights up.
2. Use the Type switch to select the string that you want to tune.

Knob Position	Description
5B	Open fifth string of a five-string bass with an additional low string (B)
4E	Open fourth string (E)
3A	Open third string (A)
2D	Open second string (D)
1G	Open first string (G)
1C	Open first string of a six-string bass with an additional high string (C)
A \flat	Open third string (semitone down) (A \flat)
A $\flat\flat$	Open third string (whole tone down) (G)

* The reference pitch is A=440 Hz. This cannot be changed.

3. Play a single note on the open string that you want to tune.

Tune the string until the green indicator lights.

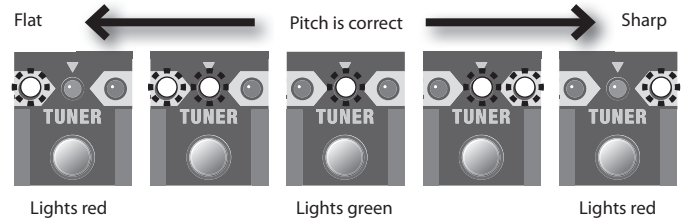

* The red indicator blinks if the pitch is substantially out of tune.

4. When you have finished tuning, press the [TUNER] switch once again.

Chromatic Tuning

If you hold down the [TUNER] switch for one second or longer, the [TUNER] switch blinks and the unit becomes usable as a "chromatic tuner," which automatically determines the name of the note closest to the one played.

As with manual tuning, chromatic tuning allows you to play a single note on the string that you want to tune. Tune the string until the green indicator lights.

Using the SOLO Function

You can save and call up the panel settings (those enclosed by the line in the figure) for sounds you create. On this unit, this function is called "SOLO." This is a convenient way to switch between a backing sound and a solo sound.

With the factory settings, the sample setting "HEAVY BOTTOM" (p. 16) is saved.

CUBE-60XL BASS

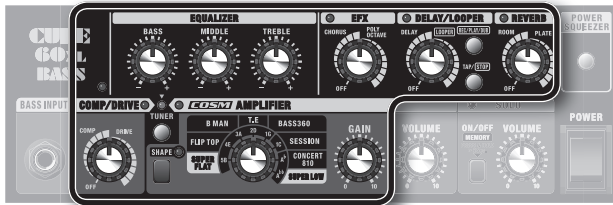

CUBE-120XL BASS

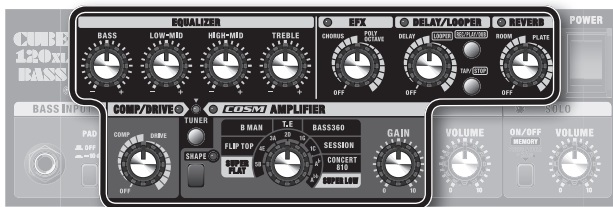

Saving the Panel Settings

1. Set the SOLO [VOLUME] knob to 0.

NOTE

If the SOLO volume is set high, the sound may be unexpectedly loud when the panel settings are saved. Before saving, lower the volume to 0.



2. Create a sound.
3. Press and hold the SOLO [ON/OFF] switch on the panel for several seconds.

The indicator will blink. When the panel settings have been saved, the indicator will change from blinking to lit.

* Never switch off the power while the indicator is blinking.



4. Use the SOLO [VOLUME] knob to adjust the volume.

* Saved panel settings remain in memory even after the power is turned off.

Recalling the Saved Sound

1. With SOLO off, press the SOLO [ON/OFF] switch.

The SOLO indicator will light, and the saved panel settings will be recalled.

* If you're using the CUBE for the first time, the factory settings will be recalled.

Editing the saved settings

1. Press the SOLO [ON/OFF] switch to call up the saved settings.
2. Turn the panel knob for the item you want to change, and modify the setting.

The SOLO indicator goes out briefly when the position of the knob coincides with the position stored in memory.

3. Hold down the SOLO [ON/OFF] switch for several seconds.

The indicator will blink. When the panel settings have been saved, the indicator will change from blinking to lit.

* Never switch off the power while the indicator is blinking.

* Once the new settings have been saved, the previous settings in effect before the changes cannot be called up again.

* To quit without saving the changes, press the SOLO [ON/OFF] switch.

Note the following if you've set FOOT SW TYPE to FS-5L (LATCH)

- If a foot switch is connected to the SOLO/COMP/DRIVE jack, the SOLO [ON/OFF] switch will be inoperable.
- If SOLO is on, and a foot switch is connected to the SOLO/COMP/DRIVE, EFX/REVERB or DELAY/REC/PLAY/DUB/TAP/STOP jack, the foot switch's indicator may not match the on/off status of the CUBE's COMP/DRIVE, EFX, REVERB, or DELAY. If you want the on/off status of the CUBE's COMP/DRIVE, EFX, REVERB, or DELAY to consistently conform to the foot switch's indicator, change the setting for the CUBE-60XL BASS/CUBE-120XL BASS to "Foot Switch Priority Mode." For details, see "Using a Latch-type Foot Switch" (p. 11).
- In order to be able to save the panel settings, you first need to switch on SOLO using the foot switch.

Returning to the Factory-default Settings

Hold down the [TAP/STOP] switch and the SOLO [ON/OFF] switch at the same time and switch on the power. The SOLO indicator blinks and the settings saved with the SOLO function are returned to their factory defaults.

Using the LOOPER

This function lets you record a phrase you perform, and then play it back repeatedly. You can also overdub additional phrases onto the recording.

On the CUBE-60XL BASS/CUBE-120XL BASS, this is called the LOOPER function.

You can also operate the LOOPER function using optional foot switches.

* The recorded phrase is deleted when the unit is turned off.

Recording a Phrase

Press the [REC/PLAY/DUB] switch to recording a phrase.

The basic operation will change as follows according to the state of the phrase.

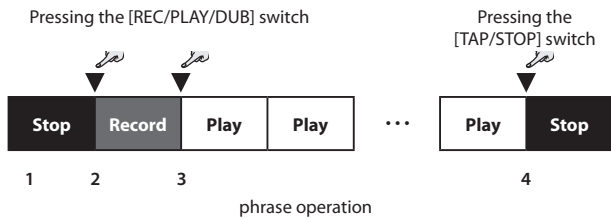

1. Set the [DELAY/LOOPER] knob at LOOPER.

Set the knob at the maximum setting. With the knob at the maximum, the phrase will be played back at the same volume as when it was recorded.



2. Press the [REC/PLAY/DUB] switch to start recording.

When you press the [REC/PLAY/DUB] switch it will blink red, and you'll enter recording-standby mode. When you start playing, the indicator will change from blinking to steadily lit, and recording will begin.

* If instead you depress the REC/PLAY/DUB footswitch, the [REC/PLAY/DUB] switch lights in red, and recording starts immediately. For details on connecting footswitches, refer to "FOOT SW" (p. 9)

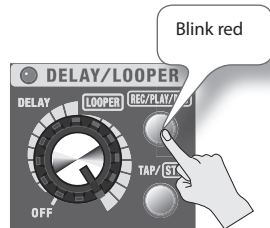

3. Press the [REC/PLAY/DUB] switch to stop recording.

At the same time that you press the [REC/PLAY/DUB] switch, the [REC/PLAY/DUB] switch lights in green and the recorded phrase will switch to playback.

The phrase will continue playing repeatedly until you stop it.

4. To stop playback or overdubbing, press the [TAP/STOP] switch.

The phrase will stop playing.

If you want to play again, press the [REC/PLAY/DUB] switch.

MEMO

If a phrase has already been recorded, the PLAY indicator will blink green.

Playing back the phrase

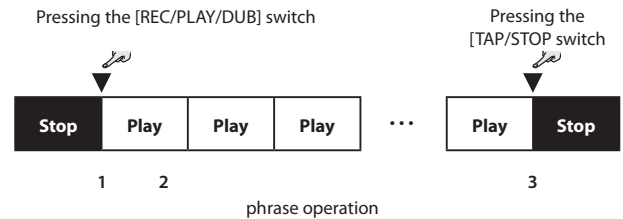

1. With the [REC/PLAY/DUB] switch blinking green, press the [REC/PLAY/DUB] switch.

* [REC/PLAY/DUB] will be unlit if no phrase has been recorded.

The [REC/PLAY/DUB] switch will light in green, and the phrase will play repeatedly from the beginning.

2. Use the [DELAY/LOOPER] knob to adjust the volume of the phrase.

3. Press the [TAP/STOP] switch to stop playback.

The [REC/PLAY/DUB] switch will blink green.

Overdubbing the phrase

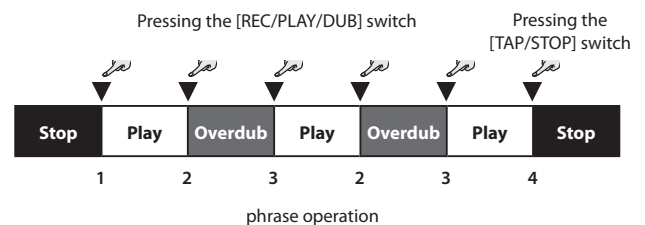

1. With the [REC/PLAY/DUB] switch blinking green, press the [REC/PLAY/DUB] switch.

The [REC/PLAY/DUB] switch will light in green, and the phrase will play repeatedly from the beginning.

2. Press the [REC/PLAY/DUB] switch once again.

The [REC/PLAY/DUB] switch will light in orange, and overdubbing will begin.

3. To stop recording, press the [REC/PLAY/DUB] switch.

The [REC/PLAY/DUB] switch will light in green, and the phrase will play repeatedly from the beginning.

4. Press the [TAP/STOP] switch to stop playback.

The [REC/PLAY/DUB] switch will blink green.

Erasing the phrase

1. Hold down the [TAP/STOP] switch for two or more seconds.

The [REC/PLAY/DUB] switch will blink red, and the phrase will be erased.

* The erased phrase cannot be recovered.

Using the LOOPER Function and DELAY at the Same Time

By taking advantage of the SOLO function, you can use the LOOPER function and the DELAY at the same time.

Normally, you cannot use the DELAY when the [DELAY/LOOPER] knob is in the LOOPER position. However, if panel settings that use the DELAY are stored in the SOLO function, and you then turn SOLO on, you'll be able to use the DELAY while using the LOOPER function.

- * Switching the DELAY on or off or changing the delay time is not possible.

Copyright

- * Recording, duplication, distribution, sale, lease, performance, or broadcast of copyrighted material (musical works, visual works, broadcasts, live performances, etc.) belonging to a third party in part or in whole without the permission of the copyright owner is forbidden by law.
- * Do not use this unit for purposes that could infringe on a copyright held by a third party. We assume no responsibility whatsoever with regard to any infringements of third-party copyrights arising through your use of this unit.

Sample Settings

HEAVY BOTTOM (SUPER LOW)

CUBE-60XL BASS



[SHAPE] Switch: OFF

CUBE-120XL BASS

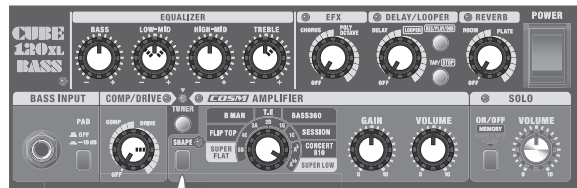

[SHAPE] Switch: OFF

In addition to its wide-range frequency response, this original amp also provides for the reproduction of heavy, deeply resonating bass sounds. You should be able to hear a bass sound with a tone quality that is different than what you would obtain if you simply boosted the bass range using an equalizer.

The [BASS] knob should be positioned in the center, so that the lower end doesn't resonate too heavily.

If you raise the [TREBLE] knob, thus emphasizing the string friction sound, you will be able to reproduce the finest nuances of instances when the strings are touched.

By lowering the [MIDDLE] or [LOW-MID] knob, you'll be able to obtain a sound with an even wider range. Conversely, if you raise the [MIDDLE] knob or the [LOW-MID] knob, and turn on DRIVE, you'll be able to create a broad variety of sounds, even aggressive rock sounds.

ALL ROUND (SUPER FLAT)

CUBE-60XL BASS



[SHAPE] Switch: OFF

CUBE-120XL BASS



[SHAPE] Switch: OFF

An original amp featuring a wide-range frequency response.

This amp type enables clear reproduction of your instrument's sound. This also makes it perfect when connecting bass modeling processors or using sound modules like bass synth.

In addition, you can exploit the equalizer's capabilities to create the perfect bass sound for any musical genre from rock to jazz

SLAP BASS (SESSION)

CUBE-60XL BASS



[SHAPE] Switch: ON or OFF

CUBE-120XL BASS



[SHAPE] Switch: ON or OFF

This setting cuts the midrange for a great slap bass sound.

Setting the [SHAPE] switch to ON further boosts the low and high ends.

To get a crisp slap sound, lower the [MIDDLE] knob or the [HIGH-MID] knob setting and raise the [TREBLE] knob. This emphasizes the brightness of the string sound, resulting in a slap sound with a lighter pull sound.

To get that attacking sound used in rock music, raise the [BASS] knob and [MIDDLE] knob or [HIGH-MID] knob settings to produce a sound with greater power. In addition, in the case of the CUBE-120XL BASS, if you lower the [LOW-MID] knob, you can obtain a sound that is deep and heavy, yet has great definition.

FINGER & FRETLESS (BASS 360)

CUBE-60XL BASS

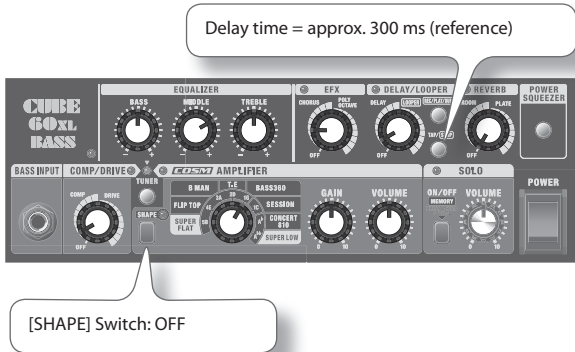

CUBE-120XL BASS

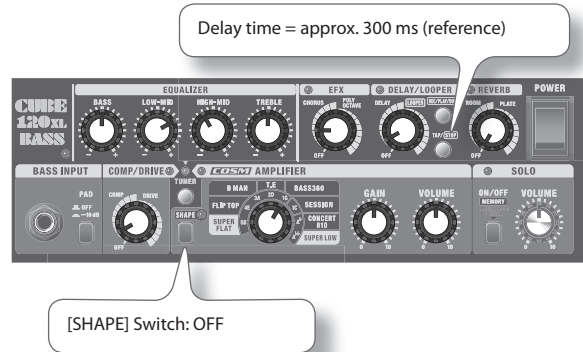

This bass sound made its appearance in the '70s.

This is suited for a Jazz Bass with a rear pickup used. This produces a warm, contoured sound when the bass is fingered near the rear pickup.

In addition, using this setting while playing harmonics in combination with a chorus and a delay enables sounds featuring exquisite reverberation.

ROCK RIFF (CONCERT 810)

CUBE-60XL BASS

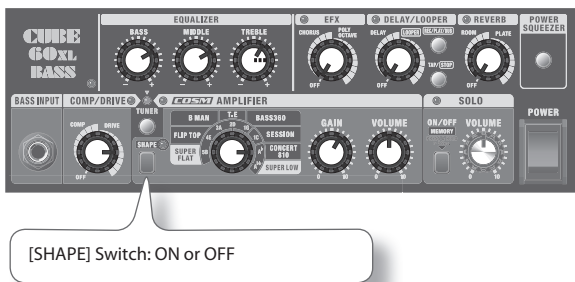

CUBE-120XL BASS



This is a drive sound that offers an extreme level of distortion, making it suitable for modern rock.

Raise [TREBLE] knob slightly in order to bring out the edginess of the picking sound.

If you turn on the [SHAPE] switch, the lower end will be emphasized and you'll obtain a fat, powerful sound.

Additionally, if you raise [MIDDLE] knob or [HIGH-MID] knob, you'll be able to obtain a deeply distorted sound that still retains a great deal of definition, even when playing in a band.

MELLOW COMP (FLIP TOP)

CUBE-60XL BASS

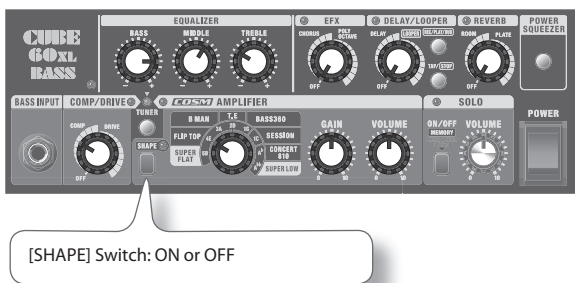

CUBE-120XL BASS



This is a sweet sound suitable for finger picking.

By applying compression deeply, and adding a little bit of reverb, you can obtain a sound that sustains well.

Also, if you apply chorus when you play melodies, you'll get a sound that has lots of presence.

If you're creating a jazz sound and want it to be warm and smooth, turn ON [SHAPE] switch, and lower [TREBLE] knob so that the picking sound does not become obtrusive.

English

Deutsch

Français

Italiano

Español

Português

Nederlands

CUBE-60XL BASS Block Diagram

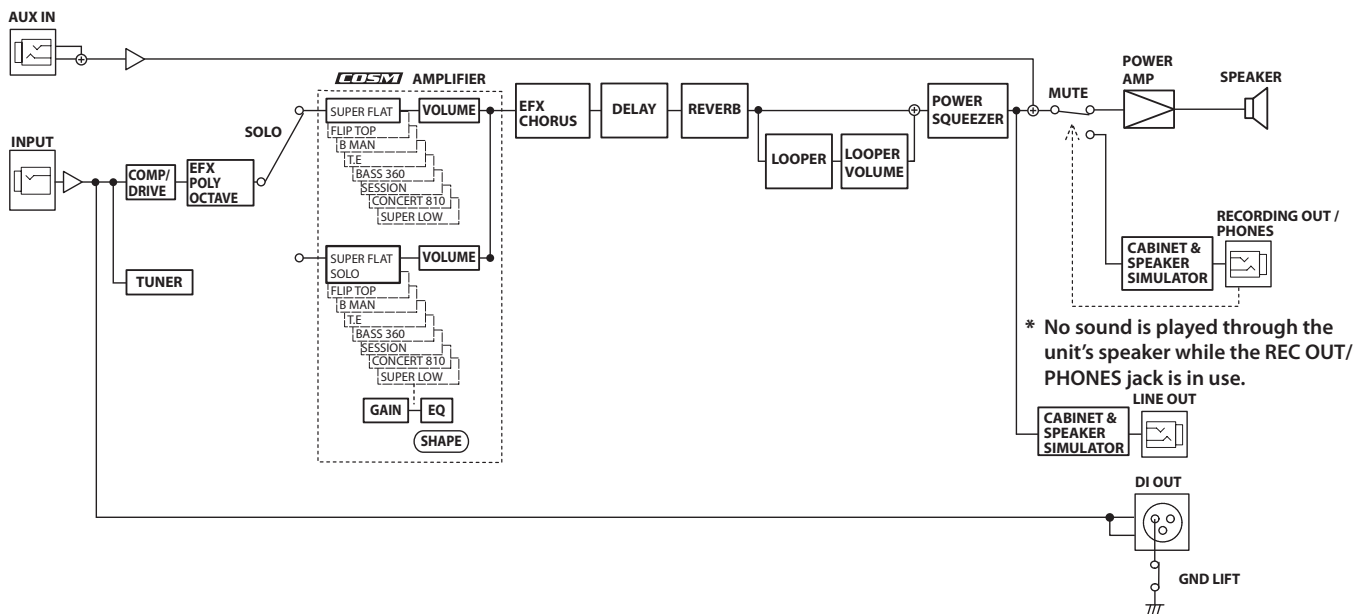

CUBE-120XL BASS Block Diagram

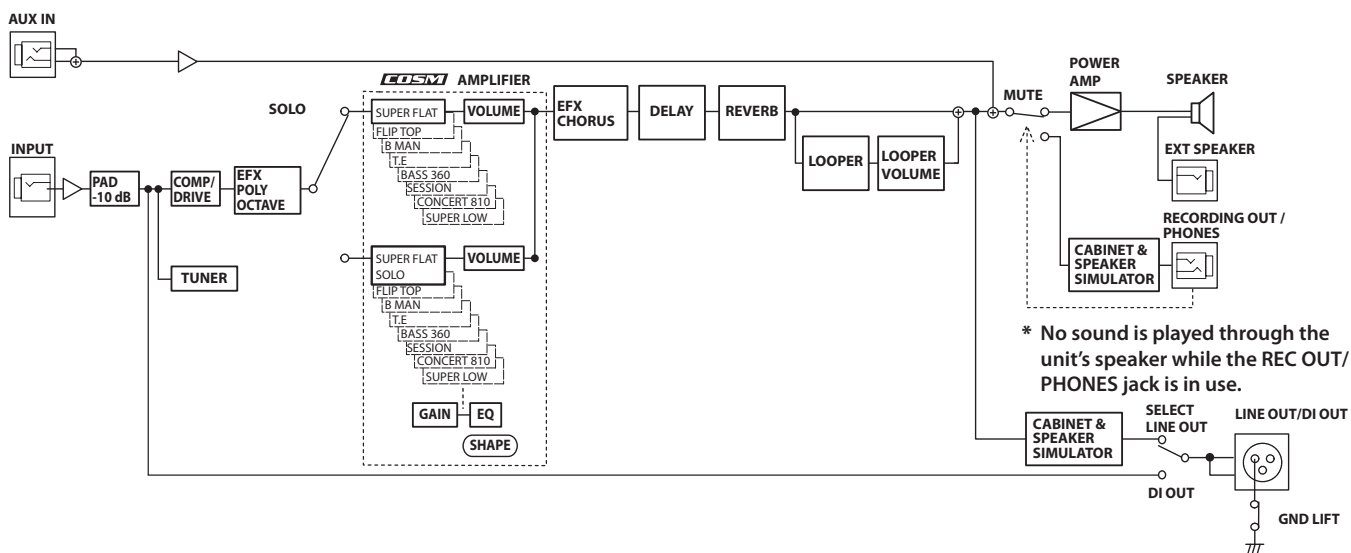

Specifications

CUBE-60XL BASS/CUBE-120XL BASS : Bass Amplifier (CB-60XL/CB-120XL)

	CUBE-60XL BASS	CUBE-120XL BASS
Rated Power Output	60 W	120 W
Nominal Input Level (@ 1 kHz)	BASS INPUT: -10 dBu/1 MΩ	BASS INPUT: -10 dBu/ 1MΩ
	AUX IN: -10 dBu	AUX IN: -10 dBu
Speaker	25 cm (10 inches)	30 cm (12 inches)
Controls	[POWER] switch	[POWER] switch
	[SHAPE] switch	[SHAPE] switch
	[TUNER] switch	[TUNER] switch
	[POWER SQUEEZER] switch	—
	[COMP/DRIVE] knob	[COMP/DRIVE] knob
	<COSM AMP> Type switch (SUPER FLAT, FLIP TOP, B MAN, T.E, BASS 360, SESSION, CONCERT 810, SUPER LOW), [GAIN] knob, [VOLUME] knob	<COSM AMP> Type switch (SUPER FLAT, FLIP TOP, B MAN, T.E, BASS 360, SESSION, CONCERT 810, SUPER LOW), [GAIN] knob, [VOLUME] knob
	<SOLO> [SOLO] switch, [VOLUME] knob	<SOLO> [SOLO] switch, [VOLUME] knob
	<EQUALIZER> [BASS] knob, [MIDDLE] knob, [TREBLE] knob	<EQUALIZER> [BASS] knob, [LOW-MID] knob, [HIGH-MID] knob, [TREBLE] knob
	<EFX> [EFX] knob (CHORUS, POLY OCTAVE)	<EFX> [EFX] knob (CHORUS, POLY OCTAVE)
	<DELAY/LOOPER> [REC/PLAY/DUB] switch [DELAY/LOOPER] knob [TAP/STOP] switch	<DELAY/LOOPER> [REC/PLAY/DUB] switch [DELAY/LOOPER] knob [TAP/STOP] switch
	<REVERB> [REVERB] knob (ROOM/PLATE)	<REVERB> [REVERB] knob (ROOM/PLATE)
	—	LINE OUT/DI OUT [SELECT] switch (LINE OUT/DI OUT)
	[GND LIFT] switch (ON/OFF)	[GND LIFT] switch (ON/OFF)
—	[FOOT SW TYPE] switch (FS-5L/FS-5U)	
Indicators	Power, COMP/DRIVE, SOLO, TUNER, EFX, DELAY/LOOPER, REC/PLAY/DUB, REVERB, POWER SQUEEZER	Power, COMP/DRIVE, SOLO, TUNER, EFX, DELAY/LOOPER, REC/PLAY/DUB, REVERB
Connectors	BASS INPUT Jack (1/4" phone type), AUX IN Jack (Stereo miniature phone type), LINE OUT Jack (1/4" phone type), DI OUT Jack (XLR type), RECORDING OUT/PHONES Jack (Stereo 1/4" phone type), FOOT SW Jack (SOLO, COMP/DRIVE) (1/4" TRS phone type), FOOT SW Jack (EFX, REVERB) (1/4" TRS phone type), FOOT SW Jack (DELAY/REC/PLAY/DUB, TAP/STOP) (1/4" TRS phone type)	BASS INPUT Jack (1/4" phone type), AUX IN Jack (Stereo miniature phone type), LINE OUT/DI OUT Jack (XLR type), RECORDING OUT/PHONES Jack (Stereo 1/4" phone type), EXT SPEAKER Jack (1/4" phone type), FOOT SW Jack (SOLO, COMP/DRIVE) (1/4" TRS phone type), FOOT SW Jack (EFX, REVERB) (1/4" TRS phone type), FOOT SW Jack (DELAY/REC/PLAY/DUB, TAP/STOP) (1/4" TRS phone type)
Power Consumption	25 W	39 W
Dimensions	421 (W) × 325 (D) × 479 (H) mm 16-5/8 (W) × 12-13/16 (D) × 18-7/8 (H) inches	462 (W) × 325 (D) × 518 (H) mm 18-3/16 (W) × 12-13/16 (D) × 20-7/16 (H) inches
Weight	16.2 kg / 35 lbs 12 oz	19.7 kg / 43 lbs 7 oz
Accessory	Owner's Manual	Owner's Manual
Options	Foot Switch (BOSS FS-5L, FS-5U, FS-6)	Foot Switch (BOSS FS-5L, FS-5U, FS-6)

* 0 dBu = 0.775 Vrms

* In the interest of product improvement, the specifications and/or appearance of this unit are subject to change without prior notice.

English

Deutsch

Français

Italiano

Español

Português

Nederlands

Roland

Information

When you need repair service, call your nearest Roland Service Center or authorized Roland distributor in your country as shown below.

AFRICA

EGYPT

Al Fanny Trading Office
9, EBN Hagar Al Askalany Street,
ARD E1 Golf, Heliopolis,
Cairo 11341, EGYPT
TEL: (022)-417-1828

REUNION

MARCEL FO-YAM Sarl
25 Rue Jules Hermann,
Chaudron - BP79 97 491
Ste Clotilde Cedex,
REUNION ISLAND
TEL: (0262) 218-429

SOUTH AFRICA

T.O.M.S. Sound & Music (Pty)Ltd.
2 ASTRON ROAD DENVER
JOHANNESBURG ZA 2195,
SOUTH AFRICA
TEL: (011) 417 3400

Paul Bothner(PTY)Ltd.

Royal Cape Park, Unit 24
Londonderry Road, Ottery 7800
Cape Town, SOUTH AFRICA
TEL: (021) 799 4900

ASIA

CHINA

Roland Shanghai Electronics Co.,Ltd.
5F, No.1500 Pingliang Road
Shanghai 200090, CHINA
TEL: (021) 5580-0800

Roland Shanghai Electronics Co.,Ltd. (BEIJING OFFICE)

10F, No.18 3 Section Anhuaxili
Chaoyang District Beijing
100011, CHINA
TEL: (010) 6426-5050

HONG KONG

Tom Lee Music
11/F Silvercord Tower 1
30 Canton Rd
Tsimshatsui, Kowloon,
HONG KONG
TEL: 825-2737-7688

Parsons Music Ltd.

8th Floor, Railway Plaza, 39
Chatham Road South, T.S.T,
Kowloon, HONG KONG
TEL: 2333 1863

INDIA

Rivera Digitec (India) Pvt. Ltd.
411, Nirman Kendra Mahalaxmi
Flats Compound Off. Dr. Edwin
Moses Road, Mumbai-400011,
INDIA
TEL: (022) 2493 9051

INDONESIA

PT Citra Intirama
Jl. Cideng Timur No. 15J-15O
Jakarta Pusat,
INDONESIA
TEL: (021) 6324170

KOREA

Cosmos Corporation
1461-9, Seocho-Dong,
Seocho Ku, Seoul, KOREA
TEL: (02) 3486-8855

MALAYSIA

Roland Asia Pacific Sdn. Bhd.
45-1, Block C2, Jalan PJU 1/39,
Dataran Prima, 47301 Petaling
Jaya, Selangor, MALAYSIA
TEL: (03) 7805-3263

VIET NAM

VIET THUONG CORPORATION
386 CACH MANG THANG TAM ST.
DIST.3, HO CHI MINH CITY,
VIET NAM
TEL: (08) 9316540

PHILIPPINES

G.A. Yupangco & Co. Inc.
339 Gil J. Puyat Avenue
Makati, Metro Manila 1200,
PHILIPPINES
TEL: (02) 899 9801

MALAYSIA/ SINGAPORE

Roland Asia Pacific Sdn. Bhd.
45-1, Block C2, Jalan PJU 1/39,
Dataran Prima, 47301 Petaling
Jaya, Selangor, MALAYSIA
TEL: (03) 7805-3263

TAIWAN

ROLAND TAIWAN ENTERPRISE CO., LTD.
9F-5, No. 112 Chung Shan
North Road Sec. 2 Taipei 104,
TAIWAN R.O.C.
TEL: (02) 2561 3339

THAILAND

Theera Music Co., Ltd.
100-108 Soi Verng Nakornkasem,
New Road, Sumpantawong,
Bangkok 10100, THAILAND
TEL: (02) 224-8821

OCEANIA

AUSTRALIA/ NEW ZEALAND

**Roland Corporation
Australia Pty.,Ltd.**
38 Campbell Avenue
Dee Why West. NSW 2099,
AUSTRALIA

For Australia
TEL: (02) 9982 8266
For New Zealand
TEL: (09) 3098 715

CENTRAL/LATIN AMERICA

ARGENTINA

Instrumentos Musicales S.A.
Av.Santa Fe 2055
(1123) Buenos Aires, ARGENTINA
TEL: (011) 4508-2700

BARBADOS

A&B Music Supplies LTD
12 Webster Industrial Park
Wildey, St.Michael, BARBADOS
TEL: (246) 430-1100

BRAZIL

Roland Brasil Ltda.
Rua San Jose, 211
Parque Industrial San Jose
Cotia - Sao Paulo - SP, BRAZIL
TEL: (011) 4615 5666

CHILE

Comercial Fancyl II S.A.
Rut: 96.919.420-1
Natanuel Cox #739, 4th Floor
Santiago - Centro, CHILE
TEL: (02) 688-9540

COLOMBIA

Centro Musical Ltda.
Cra 43 B No 25 A 41 Bododega 9
Medellin, COLOMBIA
TEL: (574) 3812529

COSTA RICA

JUAN Bansbach Instrumentos Musicales
Ave.1. Calle 11, Apartado 10237,
San Jose, COSTA RICA
TEL: 258-0211

CURACAO

Zeelandia Music Center Inc.
Orionweg 30
Curacao, Netherland Antilles
TEL: (305) 5926866

DOMINICAN REPUBLIC

Instrumentos Fernando Giraldez
Calle Proyecto Central No.3
Ens.La Esperilla
Santo Domingo,
DOMINICAN REPUBLIC
TEL: (809) 683 0305

ECUADOR

Mas Musica
Rumichaca 822 y Zaruma
Guayaquil - ECUADOR
TEL: (593-4) 2302364

EL SALVADOR

OMNI MUSIC
75 Avenida Norte y Final Alameda
Juan Pablo II,
Edificio No.4010 San Salvador,
EL SALVADOR
TEL: 262-0788

GUATEMALA

Casa Instrumental
Calzada Roosevelt 34-01,zona 11
Ciudad de Guatemala,
GUATEMALA
TEL: (502) 599-2888

HONDURAS

Almacen Pajaro Azul S.A. de C.V.
BO.Paz Barahona
3 Ave.11 Calle S.O
San Pedro Sula, HONDURAS
TEL: (504) 553-2029

MARTINIQUE

Musique & Son
Z.I.Les Mangle
97232 Le Lamantin,
MARTINIQUE F.W.I.
TEL: 596 596 426860

Gigamusic SARL

10 Rte De La Folie
97200 Fort De France
MARTINIQUE F.W.I.
TEL: 596 596 715222

MEXICO

Casa Veerkamp, s.a. de c.v.
Av. Toluca No. 323, Col. Olivar
de los Padres 01780 Mexico D.F.,
MEXICO
TEL: (55) 5668-6699

NICARAGUA

**Bansbach Instrumentos
Musicales Nicaragua**
Altamira D'Este Calle Principal
de la Farmacia 5ta.Avenida
1 Cuadra al Lago.#503
Managua, NICARAGUA
TEL: (505) 277-2557

PANAMA

SUPRO MUNDIAL, S.A.
Boulevard Andrews, Albrook,
Panama City, REP. DE PANAMA
TEL: 315-0101

PARAGUAY

Distribuidora De Instrumentos Musicales
J.E. Oleary y ESQ. Manduivira
Asuncion, PARAGUAY
TEL: (595) 21 492147

PERU

Audionet
Distribuciones Musicales SAC
Juan Fanning 530
Miraflores
Lima - PERU
TEL: (511) 4461 388

TRINIDAD

AMR Ltd
Ground Floor
Maritime Plaza
Barataria TRINIDAD W.I.
TEL: (868) 638 6385

URUGUAY

Todo Musica S.A.
Francisco Acuna de Figueroa
1771
C.P.: 11.800
Montevideo, URUGUAY
TEL: (02) 924-2335

VENEZUELA

**Instrumentos Musicales
Allegro,C.A.**
Av.las industrias edf.Guitar import
#7 zona Industrial de Turumo
Caracas, VENEZUELA
TEL: (212) 244-1122

EUROPE

BELGIUM/FRANCE/ HOLLAND/ LUXEMBOURG

Roland Central Europe N.V.
Houtstraat 3, B-2260, Oevel
(Westerlo) BELGIUM
TEL: (014) 575811

CROATIA

ART-CENTAR
Degenova 3,
HR - 10000 Zagreb, CROATIA
TEL: (1) 466 8493

CZECH REP.

**CZECH REPUBLIC DISTRIBUTOR
s.r.o**
Voctárova 247/16
180 00 Praha 8, CZECH REP.
TEL: (2) 830 20270

DENMARK

Roland Scandinavia A/S
Skagerrakvej 7 Postbox 880
DK-2100 Copenhagen,
DENMARK
TEL: 3916 6200

FINLAND

**Roland Scandinavia As, Filial
Finland**
Vanha Nurmiarventie 62
01670 Vantaa, FINLAND
TEL: (0) 9 68 24 020

GERMANY/AUSTRIA

**Roland Elektronische
Musikinstrumente GmbH.**
Osterstrasse 96, 22844 Norderstedt,
GERMANY
TEL: (040) 52 60090

GREECE/CYPRUS

STOLLAS S.A.
Music Sound Light
155, New National Road
Patras 26442, GREECE
TEL: 2610 435400

HUNGARY

Roland East Europe Ltd.
2045 Torokbalint, FSD Park,
building 3., HUNGARY
TEL: (23) 511011

Ireland

Roland Ireland
G2 Calmount Park, Calmount
Avenue, Dublin 12,
Republic of IRELAND
TEL: (01) 4294444

ITALY

Roland Italy S. p. A.
Viale delle Industrie 8,
20020 Arese, Milano, ITALY
TEL: (02) 937-78300

NORWAY

**Roland Scandinavia Avd.
Kontor Norge**
Lilleakerveien 2 Postboks 95
Lilleaker N-0216 Oslo,
NORWAY
TEL: (868) 2273 0074

POLAND

ROLAND POLSKA SP. Z O.O.
ul. Kty Grodziskie 16B
03-289 Warszawa, POLAND
TEL: (022) 678 9512

PORTUGAL

Roland Iberia, S.L.
Branch Office Porto
Edificio Tower Plaza
Rotunda Eng. Edgar Cardoso
23, 9ºG
4400-676 Vila Nova de Gaia,
PORTUGAL
TEL: (+351) 22 608 00 60

ROMANIA

FBS LINES
Piata Libertatii 1,
535500 Gheorgheni, ROMANIA
TEL: (266) 364 609

RUSSIA

Roland Music LLC
Dorozhnaya ul.3,korp.6
117 545 Moscow, RUSSIA
TEL: (495) 981-4967

SERBIA

Music AP Ltd.
Sutjeska br. 5 XS - 24413 Palic,
SERBIA
TEL: (024) 539 395

SLOVAKIA

DAN Acoustic s.r.o.
Povazská 18,
SK - 940 01 Nové Zámky,
SLOVAKIA
TEL: (035) 6424 330

SPAIN

Roland Iberia, S.L.
Paseo García Faria, 33-35
08005 Barcelona, SPAIN
TEL: 93 493 91 00

SWEDEN

Roland Scandinavia A/S
SWEDISH SALES OFFICE
Märbackagatan 31, 4 tr.
SE-123 43 Farsta, SWEDEN
TEL: (0) 8 683 04 30

SWITZERLAND

Roland (Switzerland) AG
Landstrasse 5, Postfach,
CH-4452 Ittingen, SWITZERLAND
TEL: (061) 975-9987

UKRAINE

EURHYTHMICS Ltd.
P.O.Box: 37-a,
Nedecey Str. 30
UA - 89600 Mukachevo, UKRAINE
TEL: (03131) 414-40

UNITED KINGDOM

Roland (U.K.) Ltd.
Atlantic Close, Swansea
Enterprise Park, SWANSEA SA7
9FJ, UNITED KINGDOM
TEL: (01792) 702701

MIDDLE EAST

BAHRAIN

Moon Stores
No.1231&1249 Rumaytha
Building Road 3931,
Manama 339, BAHRAIN
TEL: 17 813 942

IRAN

MOCO INC.
NO.16 End of Nike St. Shariati
Ave, Roberouye Cerah Mirdamad
Teheran, IRAN
TEL: (021)-2288-2998

ISRAEL

**Halilit P. Greenspoon & Sons
Ltd.**
8 Retzif Ha'alia Hashnia St.
Tel-Aviv-Yafa ISRAEL
TEL: (03) 6823666

JORDAN

MUSIC HOUSE CO. LTD.
FREDDY FOR MUSIC
P.O. Box 922846
Amman 11192, JORDAN
TEL: (06) 5692696

KUWAIT

**EASA HUSAIN AL-YOUSIFI &
SONS CO.**
Al-Yousifi Service Center
P.O.Box 126 (Safat) 13002,
KUWAIT
TEL: 00 965 802929

LEBANON

Chahine S.A.L.
George Zeidan St., Chahine Bldg.,
Achrafieh, P.O.Box: 16-5857
Beirut, LEBANON
TEL: (01) 20-1441

OMAN

TALENTZ CENTRE L.L.C.
Malatan House No.1
Al Noor Street, Ruwi
SULTANATE OF OMAN
TEL: 2478 3443

QATAR

**AL-EMADI TRADING &
CONTRACTING CO.**
P.O. Box 62, Doha, QATAR
TEL: 4423-554

SAUDI ARABIA

**aDawlah Universal Electronics
aPL**
Behind Pizza Inn
Prince Turkey Street
aDawlah Building,
PO BOX 2154,
Alkhobar 31952,
SAUDI ARABIA
TEL: (03) 8643601

SYRIA

Technical Light & Sound Center
PO Box 13520 Bldg No.49
Khaled Abn Alwailid St.
Damascus, SYRIA
TEL: (011) 223-5384

TURKEY

ZUHAL DIS TICARET A.S.
Galip Dede Cad. No.33
Beyoglu, Istanbul, TURKEY
TEL: (0212) 249 85 10

U.A.E.

**Zak Electronics & Musical
Instruments Co. L.L.C.**
Zabeel Road, Al Sherooq Bldg.,
No. 14, Ground Floor, Dubai,
U.A.E.
TEL: (04) 3360715

NORTH AMERICA

CANADA

**Roland Canada Ltd.
(Head Office)**
5480 Parkwood Way Richmond B.
C., V6V 2M4, CANADA
TEL: (604) 270 6626

Roland Canada Ltd. (Toronto Office)

170 Admiral Boulevard
Mississauga On L5T 2N6,
CANADA
TEL: (905) 362 9707

U. S. A.

Roland Corporation U.S.
5100 S. Eastern Avenue
Los Angeles, CA 90040-2938,
U. S. A.
TEL: (323) 890 3700

有关产品中所含有害物质的说明

本资料就本公司产品中所含的特定有害物质及其安全性予以说明。

本资料适用于 2007 年 3 月 1 日以后本公司所制造的产品。

环保使用期限



此标志适用于在中国国内销售的电子信息产品，表示环保使用期限的年数。所谓环保使用期限是指在自制造日起的规定的期限内，产品中所含的有害物质不致引起环境污染，不会对人身、财产造成严重的不良影响。环保使用期限仅在遵照产品使用说明书，正确使用产品的条件下才有效。不当的使用，将会导致有害物质泄漏的危险。

产品中有毒有害物质或元素的名称及含量

部件名称	有毒有害物质或元素					
	铅(Pb)	汞(Hg)	镉(Cd)	六价铬(Cr(VI))	多溴联苯(PBB)	多溴二苯醚(PBDE)
外壳(壳体)	×	○	○	○	○	○
电子部件(印刷电路板等)	×	○	×	○	○	○
附件(电源线、交流适配器等)	×	○	○	○	○	○

○：表示该有毒有害物质在该部件所有均质材料中的含量均在 SJ/T11363-2006 标准规定的限量要求以下。
 ×：表示该有毒有害物质至少在该部件的某一均质材料中的含量超出 SJ/T11363-2006 标准规定的限量要求。
 根据现有的技术水平，还没有什么物质能够代替它。

For EU Countries



- UK** This symbol indicates that in EU countries, this product must be collected separately from household waste, as defined in each region. Products bearing this symbol must not be discarded together with household waste.
- DE** Dieses Symbol bedeutet, dass dieses Produkt in EU-Ländern getrennt vom Hausmüll gesammelt werden muss gemäß den regionalen Bestimmungen. Mit diesem Symbol gekennzeichnete Produkte dürfen nicht zusammen mit dem Hausmüll entsorgt werden.
- FR** Ce symbole indique que dans les pays de l'Union européenne, ce produit doit être collecté séparément des ordures ménagères selon les directives en vigueur dans chacun de ces pays. Les produits portant ce symbole ne doivent pas être mis au rebut avec les ordures ménagères.
- IT** Questo simbolo indica che nei paesi della Comunità europea questo prodotto deve essere smaltito separatamente dai normali rifiuti domestici, secondo la legislazione in vigore in ciascun paese. I prodotti che riportano questo simbolo non devono essere smaltiti insieme ai rifiuti domestici. Ai sensi dell'art. 13 del D.Lgs. 25 luglio 2005 n. 151.
- ES** Este símbolo indica que en los países de la Unión Europea este producto debe recogerse aparte de los residuos domésticos, tal como está regulado en cada zona. Los productos con este símbolo no se deben depositar con los residuos domésticos.
- PT** Este símbolo indica que nos países da UE, a recolha deste produto deverá ser feita separadamente do lixo doméstico, de acordo com os regulamentos de cada região. Os produtos que apresentem este símbolo não deverão ser eliminados juntamente com o lixo doméstico.
- NL** Dit symbool geeft aan dat in landen van de EU dit product gescheiden van huishoudelijk afval moet worden aangeboden, zoals bepaald per gemeente of regio. Producten die van dit symbool zijn voorzien, mogen niet samen met huishoudelijk afval worden verwijderd.
- DK** Dette symbol angiver, at i EU-lande skal dette produkt opsamles adskilt fra husholdningsaffald, som defineret i hver enkelt region. Produkter med dette symbol må ikke smides ud sammen med husholdningsaffald.
- NO** Dette symbolet indikerer at produktet må behandles som spesialavfall i EU-land, iht. til retningslinjer for den enkelte regionen, og ikke kastes sammen med vanlig husholdningsavfall. Produkter som er merket med dette symbolet, må ikke kastes sammen med vanlig husholdningsavfall.

- SE** Symbolen anger att i EU-länder måste den här produkten kasseras separat från hushållsavfall, i enlighet med varje regions bestämmelser. Produkter med den här symbolen får inte kasseras tillsammans med hushållsavfall.
- FI** Tämä merkintä ilmaisee, että tuote on EU-maissa kerättävä erillään kotitalousjätteistä kunkin alueen voimassa olevien määräysten mukaisesti. Tällä merkinnällä varustettuja tuotteita ei saa hävittää kotitalousjätteiden mukana.
- HU** Ez a szimbólum azt jelenti, hogy az Európai Unióban ezt a terméket a háztartási hulladéktól elkülönítve, az adott régióban érvényes szabályozás szerint kell gyűjteni. Az ezzel a szimbólummal ellátott termékeket nem szabad a háztartási hulladék közé dobni.
- PL** Symbol oznacza, że zgodnie z regulacjami w odpowiednim regionie, w krajach UE produktu nie należy wyrzucać z odpadami domowymi. Produktów opatrzonych tym symbolem nie można utylizować razem z odpadami domowymi.
- CZ** Tento symbol udává, že v zemích EU musí být tento výrobek sbírán odděleně od domácího odpadu, jak je určeno pro každý region. Výrobky nesoucí tento symbol se nesmí vyhazovat spolu s domácím odpadem.
- SK** Tento symbol vyjadruje, že v krajinách EÚ sa musí zber tohto produktu vykonávať oddelene od domového odpadu, podľa nariadení platných v konkrétnej krajine. Produkty s týmto symbolom sa nesmú vyhazovať spolu s domovým odpadom.
- EE** See sümbol näitab, et EL-i maades tuleb see toode olemprügist eraldi koguda, nii nagu on igas piirkonnas määratletud. Selle sümboliga märgitud tooteid ei tohi ära visata koos olemprügiga.
- LT** Šis simbolis rodo, kad ES šalyse šis produktas turi būti surenkamas atskirai nuo buitinių atliekų, kaip nustatyta kiekviename regione. Šiuo simboliu paženklinėti produktai neturi būti išmetami kartu su buitinių atliekomis.
- LV** Šis simbols norāda, ka ES valstīs šo produktu jāievāc atsevišķi no mājsaimniecības atkritumiem, kā noteikts katrā reģionā. Produkts ar šo simbolu nedrīkst izmest kopā ar mājsaimniecības atkritumiem.
- SI** Ta simbol označuje, da je treba proizvod v državah EU zbirati ločeno od gospodinskih odpadkov, tako kot je določeno v vsaki regiji. Proizvoda s tem znakom ni dovoljeno odlagati skupaj z gospodinskimi odpadki.
- GR** Το σύμβολο αυτό υποδηλώνει ότι στις χώρες της Ε.Ε. το συγκεκριμένο προϊόν πρέπει να συλλέγεται χωριστά από τα υπόλοιπα οικιακά απορρίμματα, σύμφωνα με όσα προβλέπονται σε κάθε περιοχή. Τα προϊόντα που φέρουν το συγκεκριμένο σύμβολο δεν πρέπει να απορρίπτονται μαζί με τα οικιακά απορρίμματα.



This product complies with the requirements of EMCD 2004/108/EC and LVD 2006/95/EC.

For EU Countries

FEDERAL COMMUNICATIONS COMMISSION RADIO FREQUENCY INTERFERENCE STATEMENT

For the USA

This equipment has been tested and found to comply with the limits for a Class B digital device, pursuant to Part 15 of the FCC Rules. These limits are designed to provide reasonable protection against harmful interference in a residential installation. This equipment generates, uses, and can radiate radio frequency energy and, if not installed and used in accordance with the instructions, may cause harmful interference to radio communications. However, there is no guarantee that interference will not occur in a particular installation. If this equipment does cause harmful interference to radio or television reception, which can be determined by turning the equipment off and on, the user is encouraged to try to correct the interference by one or more of the following measures:

- Reorient or relocate the receiving antenna.
- Increase the separation between the equipment and receiver.
- Connect the equipment into an outlet on a circuit different from that to which the receiver is connected.
- Consult the dealer or an experienced radio/TV technician for help.

This device complies with Part 15 of the FCC Rules. Operation is subject to the following two conditions:

- (1) this device may not cause harmful interference, and
- (2) this device must accept any interference received, including interference that may cause undesired operation.

This equipment requires shielded interface cables in order to meet FCC class B limit.

Any unauthorized changes or modifications not expressly approved by the party responsible for compliance could void the user's authority to operate the equipment.

For Canada

NOTICE

This Class B digital apparatus meets all requirements of the Canadian Interference-Causing Equipment Regulations.

AVIS

Cet appareil numérique de la classe B respecte toutes les exigences du Règlement sur le matériel brouilleur du Canada.

For C.A. US (Proposition 65)

WARNING

This product contains chemicals known to cause cancer, birth defects and other reproductive harm, including lead.

MEMO

Roland

